

SYNCHRONISED STEERING SYSTEM



MOD. 10-114 - Steering system on swivelling forks



MOD. 243-RVSE - Steering system on big steel ball-bearing fifth wheel



MOD. 43-VRSE - Steering system on big steel ball-bearing fifth wheel

FEATURES

A convoy of a tractor and several trailer trolleys travels more easily and safely when all vehicles move along the same trajectory.

Our synchronized steering system, made with rigid bars with high precision geometry, needs no maintenance and guarantees that the entire convoy follows a single track, with tolerances limited to a few millimeters.

The design begins by studying the floor plan or the size of cargo required and anticipates turning spaces with detailed drawings.

Three different steering devices depending on the conditions of travel and type of use:

- Steel fifth wheel working on continuous pre-lubricated balls
- Forks swiveling on vertical hub with load distributed on double ball bearings
- Cantilevered stub axles rotating on vertical axial hub with load distributed on double ball bearings

MOD. 10-G

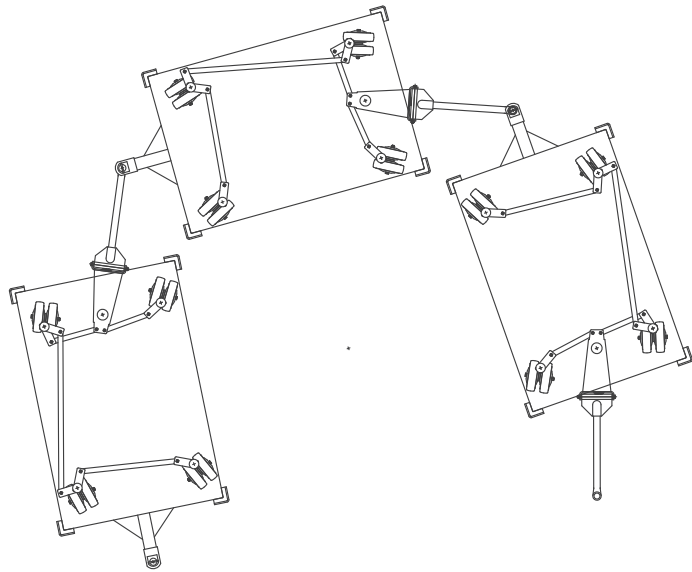

MOD. 43-VRSE

